

# Palette Case

4U, 62HP Shallow Powered Eurorack Case w/MIDI, Audio & Buff Mults



## TABLE OF CONTENTS

[TABLE OF CONTENTS](#)

[COMPLIANCE](#)

[OVERVIEW](#)

[TOP PANEL](#)

[CIRCUIT BOARD](#)

[INSTALLATION TIPS](#)

[UNDERSTANDING BUFF MULTS](#)

[TECHNICAL SPECIFICATIONS](#)

---

## COMPLIANCE



This device complies with Part 15 of the FCC Rules. Operation is subject to the following two conditions: (1) this device may not cause harmful interference, and (2) this device must accept any interference received, including interference that may cause undesired operation.

Changes or modifications not expressly approved by Intellijel Designs, Inc. could void the user's authority to operate the equipment.

Any digital equipment has been tested and found to comply with the limits for a Class A digital device, pursuant to part 15 of the FCC Rules. These limits are designed to provide reasonable protection against harmful interference when the equipment is operated in a commercial environment. This equipment generates, uses, and can radiate radio frequency energy and, if not installed and used in accordance with the instruction manual, may cause harmful interference to radio communications.



This device meets the requirements of the following standards and directives:

EMC: 2014/30/EU

EN55032:2015 ; EN55103-2:2009 (EN55024) ; EN61000-3-2 ; EN61000-3-3

Low Voltage: 2014/35/EU

EN 60065:2002+A1:2006+A11:2008+A2:2010+A12:2011

RoHS2: 2011/65/EU

WEEE: 2012/19/EU

## OVERVIEW

Intellijel's Palette case is compact enough to slip into a laptop bag, and shallow enough to rest comfortably on a desktop — yet its capabilities far exceed its size. It contains 62 HP of 3U space for mounting eurorack standard 3U modules, plus another 62 HP of 1U space for all those necessary little utility modules. In addition, each Palette contains:

- Two built-in 1x4 buffered mults (chainable into a 1 x 8) with input level/polarity LEDs
- Built-in MIDI Input (both USB and 1/8" TRS MIDI via the supplied 5-pin DIN adapter)
- Two 1/4" TRS jacks, which can function as either two outputs (ideal for configuring Palette as a synthesizer), two inputs (perfect for those using Palette as an effects processor), or an input/output combination (ideal for sending and returning signal to an external effects module or stomp box).
- Robust power circuit with 12 shrouded power connectors, capable of supplying up to 1.2A of both +12V and -12V to your Eurorack modules.
- Two 5V connectors, delivering up to 500mA between them.
- Access connectors for internally connecting I/O modules to the built-in MIDI and Audio Jacks
- Link connector for plugging supported products (like a Mixup module) directly into the 1/4" jacks.

Palette is as stylish as it is practical, as durable as it is portable; and every bit as flexible as your imagination allows.

## TOP PANEL

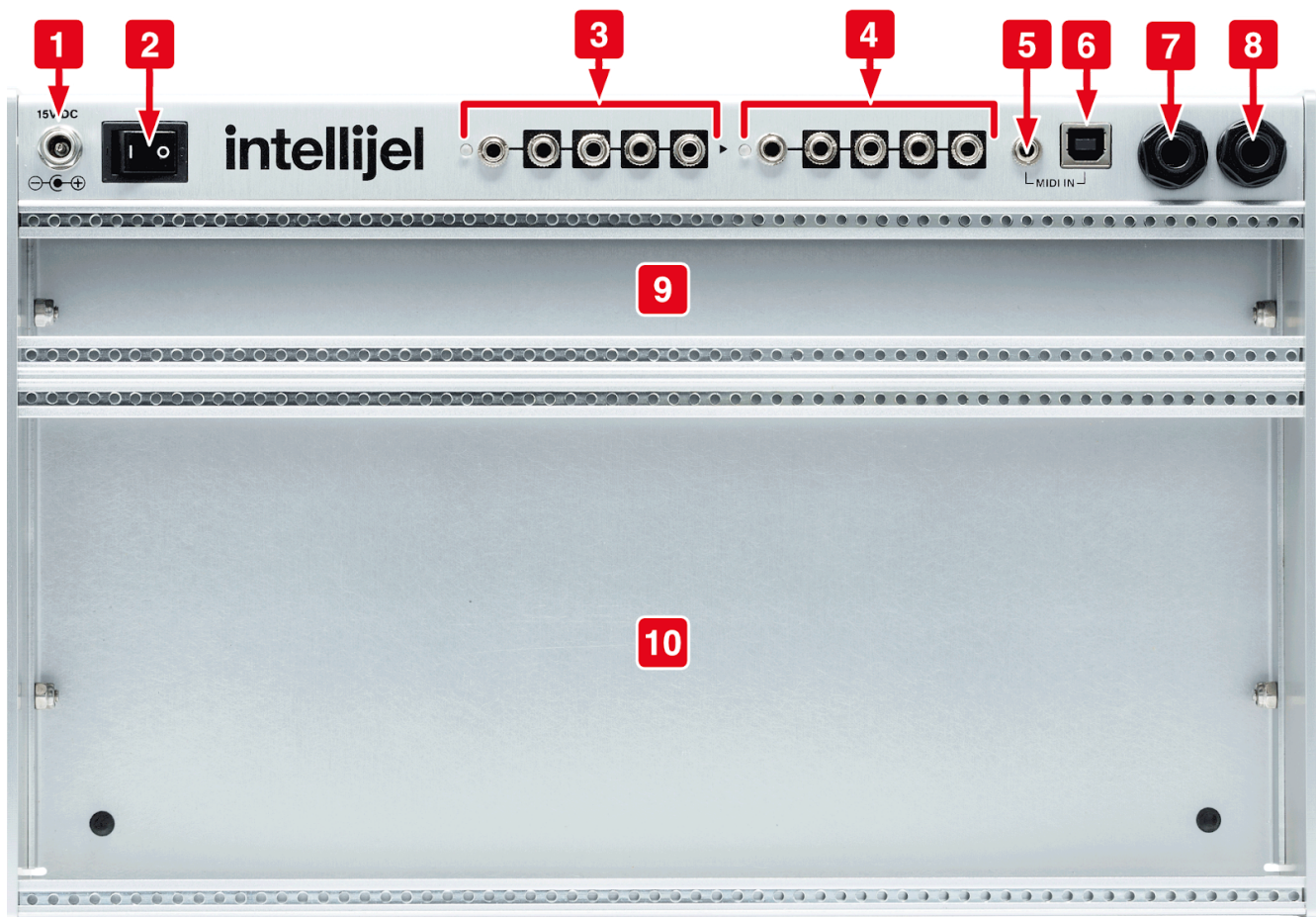

The following features can be found on the surface of your Palette Case:

**1. Power Input Socket**

Connect the included 40W, 15V center-pin-positive power adapter to this socket to provide power to your case. To insure proper power is applied to all your modules, use only Intellijel certified power adapters.

**2. Power Switch**

Switch to “I” to power up the Palette, and all its connected modules. Switch to “0” to turn it off.

### 3. Buff Mult 1

The first of two built-in 1 x 4 buffered signal multipliers. Plug an audio or CV signal into the left-most jack and a buffered duplicate of that signal appears at the four jacks to its right. For more information about Buff Mults, see [Understanding Buff Mults](#).

### 4. Buff Mult 2

The second of two built-in 1 x 4 buffered signal multipliers. Plug an audio or CV signal into its left-most jack and a buffered duplicate of that signal appears at the four jacks to its right.

Buff Mult 1 is normalled to Buff Mult 2. So if nothing is plugged into Buff Mult 2's input, then Buff Mult 1's input is duplicated across all 8 outputs, making the pair of Buff Mults act as a single 1 x 8 buffered signal multiplier.

To the left of each Buff Mult's input jack is an LED, whose brightness indicates the amount of voltage appearing at the input, and whose color indicates the polarity (with **green** signifying positive voltages, and **red** signifying negative).

For more information about Buff Mults, see [Understanding Buff Mults](#).

### 5. 1/8" TRS MIDI Input

MIDI input connector on 1/8" TRS jack socket. Use the enclosed conversion cable to connect an industry standard 5-pin DIN connector to the case. MIDI sent into this jack is routed to the 10-pin MIDI Connector socket on the Palette's [circuit board](#), where it can be connected to a MIDI input module, such as the Intellijel  $\mu$ MIDI 1U.

### 6. USB MIDI Input

MIDI input connector on USB. MIDI sent into the USB port is routed to the 10-pin MIDI Connector socket on the Palette's [circuit board](#), where it can be connected to a MIDI input module, such as the Intellijel  $\mu$ MIDI 1U.

### 7. TRS Audio Jack 1

This 1/4" Neutrik TRS jack (and the one beside it) can operate as either an audio input or an audio output depending on which modules you connect to the circuit board inside the Palette case. This allows you maximum flexibility when configuring your case — whether you wish to use these audio jacks as outputs for a Palette-based synthesizer; as inputs for a Palette-based effects device; or as a send/return for plugging external pedals or effects devices into your Palette's signal chain.

These jacks may be used with any one of the following modules:

- **Stereo Line Out 1U**: This module, when connected to the Audio Jacks Connector on the [circuit board](#), sends balanced +4dBu audio out the two 1/4" TRS jacks.
- **Stereo Line In 1U**: This module, when connected to the Audio Jacks Connector on the [circuit board](#), receives balanced +4dBu audio input from the two 1/4" TRS jacks.

*Note: The Stereo Line In 1U module is not yet available.*

- **Pedal I/O 1U:** This module, when connected to the Link Connector on the [circuit board](#), sends an unbalanced line-level output to Jack 1, and returns an unbalanced live-level input on Jack 2. Use this module to patch external effects or stomp boxes into your Palette.
- **Mixup 3U:** This module, when connected to the Link Connector on the [circuit board](#), sends the unbalanced L/R stereo mix from the rear-panel output of Mixup directly to the two ¼" jacks on Palette.

***Important:** You cannot connect multiple modules to these ¼" TRS jacks. Unexpected results may occur if you attach multiple and competing audio jacks modules to the circuit board.*

#### **8. TRS Audio Jack 2**

A second configurable ¼" Neutrik TRS jack, which operates in conjunction with TRS Audio Jack 1, described above.

#### **9. 62 HP for mounting 1U modules**

62 hp of mounting space for Intellijel format 1U modules.

#### **10. 62 HP for mounting 3U modules**

62 hp of mounting space for 3U modules up to a depth of 45.5mm. At each of the extreme edges (occupying less than 1 hp) there is a depth of 37.42mm.

## CIRCUIT BOARD

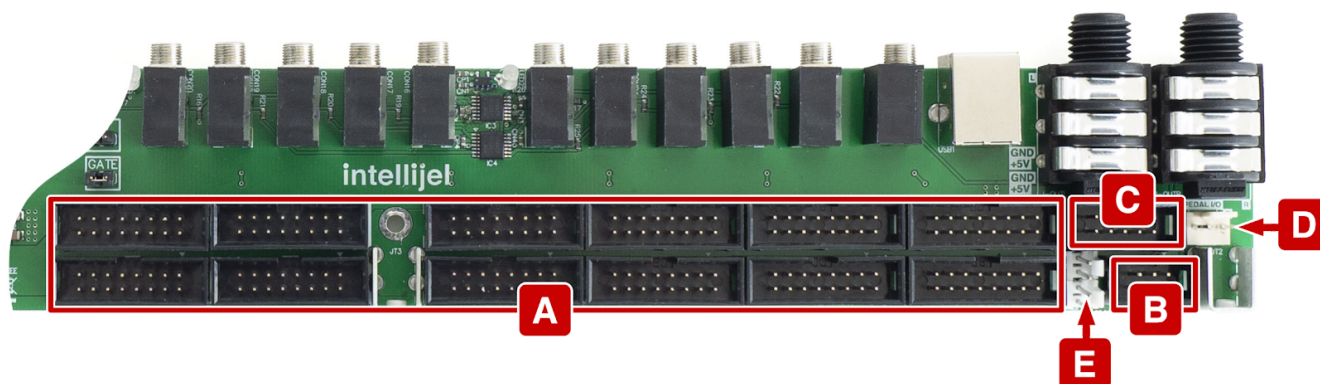

Running along the back edge of the Palette is its built-in circuit board, which contains all of Palette’s audio, midi, power, and module connection circuitry.

The jacks and switches that run along the top of the circuit board were discussed earlier in the [Top Panel](#) description. Below these jacks and switches, and facing into the case, are the various headers needed to connect your gear. These are:

### A. Power Connectors (x12)

Twelve 16-pin power connectors for powering your modules. The connectors are shrouded to insure that properly manufactured ribbon cables can be connected only one way — with the red (-12V) wire to the right.

Make sure, if you’re using cables from another manufacturer or sourced elsewhere, that the red stripe is on the right when plugged in.

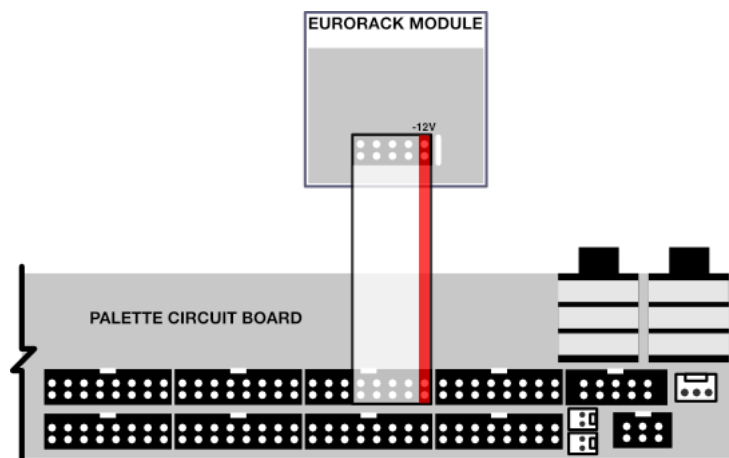

Plug the other end of the ribbon cables into the Eurorack modules you wish to power — being careful (if the module’s power connector isn’t shrouded) to align the red stripe with the -12V pins on the module. These pins are indicated differently by different manufacturers, but often will say “-12V,” or “Red Stripe,” or have a visible white stripe next to the -12V side of the connector. See your Eurorack modules for details concerning its -12V power nomenclature.



**B. Audio Jacks Connector**

Use this 6-pin connector for attaching either a balanced audio input or balanced audio output module to the 1/4" TRS connectors on the top of the Palette. Specifically, you may connect:

- **Stereo Line Out 1U:** Using the cable provided with your Stereo Line Out 1U module, connect it to the Audio Jacks Connector. Once connected, Palette's two TRS audio jacks function as L/R audio outputs for the Palette case.

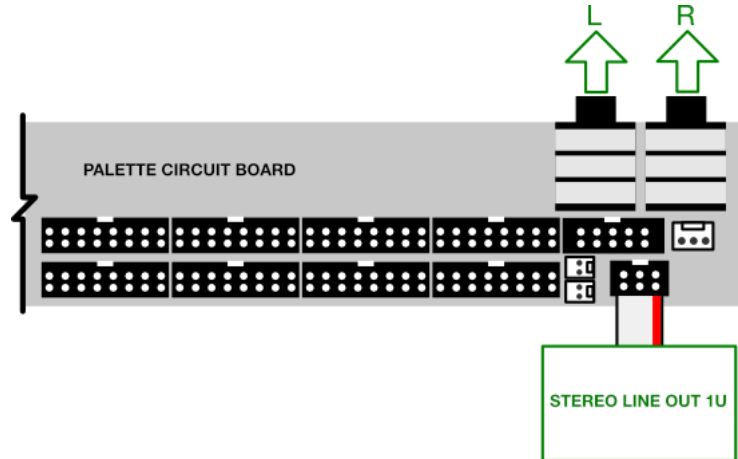

- **Stereo Line In 1U:** Using the cable provided with your Stereo Line In 1U module, connect it to the Audio Jacks Connector. Once connected, Palette's two TRS audio jacks function as L/R audio inputs for the Palette case.

*NOTE: This module is not yet available.*

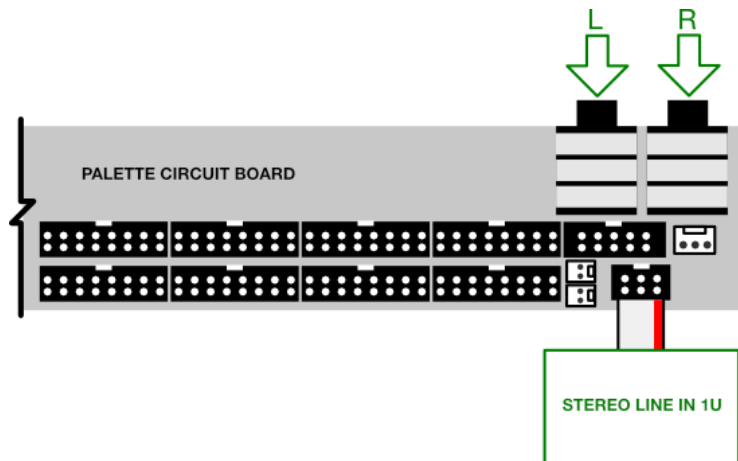

**IMPORTANT:** *If you connect a module to the Audio Jacks Connector, you should not connect a module to the Link Connector (described below). Since both connectors access the Audio Jacks on your Palette case, unexpected results may occur.*

**C. MIDI Connector**

Connect the cable included with your Intellijel  $\mu$ MIDI 1U module to this 10-pin connector to use the Palette's USB and 1/8" TRS MIDI Jacks as MIDI inputs for the  $\mu$ MIDI 1U.

**D. Link Connector**

Use this 3-pin connector to attach either a Mixup module or a Pedal I/O module to the two ¼” connectors on the top of the Palette.

- **Mixup:** Connect the 3-wire link cable (provided with your Mixup module), between the Link Connector on the Palette circuit board and the CHAIN-OUT connector on your Mixup.

In this scenario, unbalanced stereo audio from Mixup’s output is sent out Palette’s two Audio Jacks.

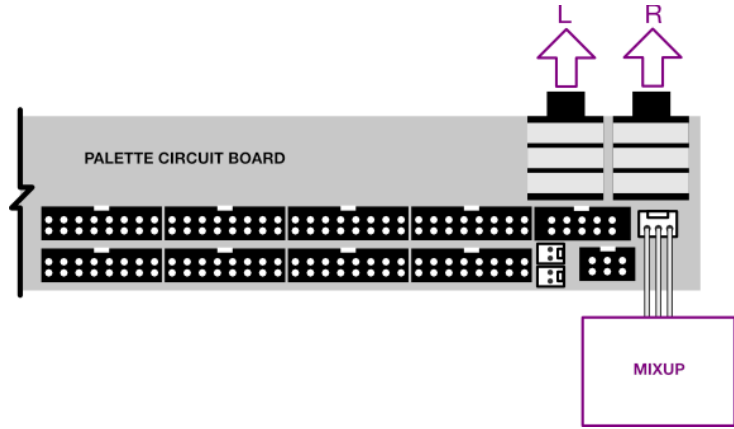

- **Pedal I/O 1U:** Connect the 3-wire link cable (provided with your Pedal I/O module), between the Link Connector on the Palette circuit board and the one on your Pedal I/O.

In this scenario, unbalanced audio is sent out Audio Jack 1 to your external signal processor, and unbalanced audio comes back from your external signal processor into Audio Jack 2.

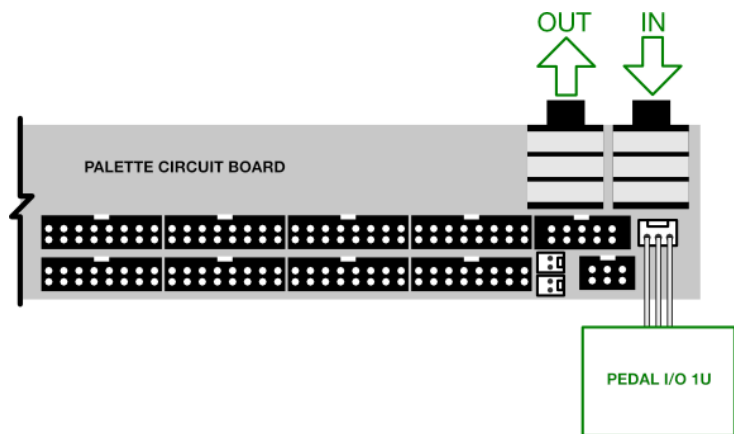

**IMPORTANT:** *If you connect a module to the Links Connector, you should not connect a module to the Audio Jacks Connector (described previously). Since both connectors access the Audio Jacks on your Palette case, unexpected results may occur.*

**E. 5V Connectors**

Connect these 5V connectors to any modules that require a 5V power source. You can also use this to power an Intellijel USB Power 1U module, which (for example) is useful for connecting a small USB gooseneck LED light.

## INSTALLATION TIPS

Palette was designed to provide maximum performance and compatibility in the smallest possible space. Because of this, and in accordance with those pesky little laws of physics, it can sometimes be a little tedious to plug and unplug the various cables into the circuit board at the rear of the case.

Fortunately, there are a couple of things you can do to make the process quicker and easier:

- With the case completely empty, connect all of your power, link, 5V, 5-pin audio, and 10-pin MIDI cables to the Palette circuit board first. If you think you might swap out modules in the future (and, since this is Eurorack, you probably will), then it's a good idea to connect a few more power cables to the circuit board than you currently need — that will make it easier to add additional modules in the future.
- The circuit board is much more accessible if you first remove the top rail. With the rail removed, it's much easier to plug the various connectors into the circuit board. To do this:
  1. Remove the two screws (one on each side of the case) that hold the top rail in place. Make note of the rail's orientation, and set it aside.

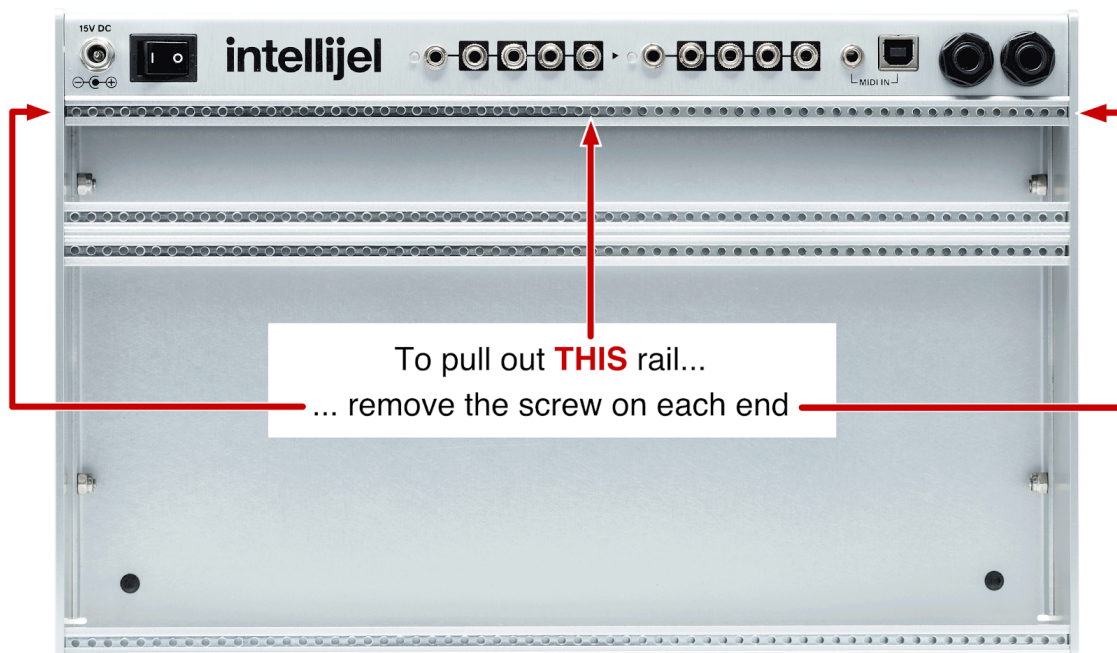

2. Connect all the necessary cables to the circuit board.
3. Slide the rail back into place, and re-insert the screws on either side.
4. Connect the cables to all your modules and screw them into the rails.

## UNDERSTANDING BUFF MULTS

“Buff Mult” is vernacular shorthand for “Buffered Multiplier.” A buff mult takes a single input signal and routes it to multiple outputs simultaneously. For example, you might want to route a keyboard’s pitch CV to three different destinations: one to govern the pitch of your main oscillator; another to govern the pitch of a second oscillator; and the third to open and close a filter so that it tracks across the keyboard.

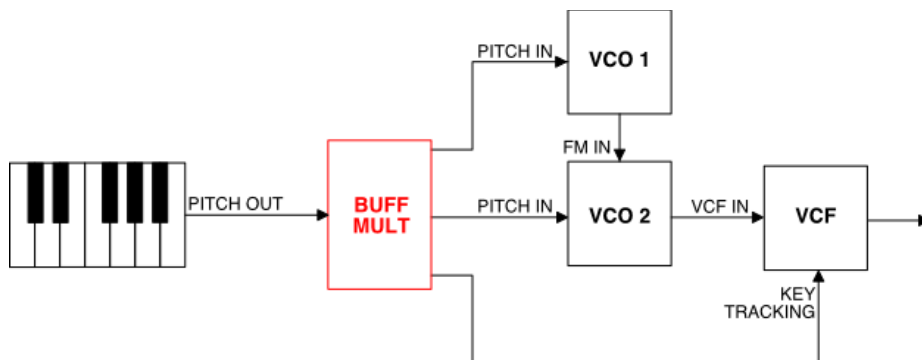

Unlike a passive mult, which merely splits the incoming signal and shares it across multiple outputs (much like a Y-cable), buffered mults make electrical copies of an input voltage and duplicate that voltage at the outputs.

Buffered mults have a few advantages over passive mults. Because buffered mults isolate their outputs from the input, any faults or shorts present at the input will not pass through to a connected module. Also, in a passive mult, what you connect to an output can cause a slight variation in the voltages that it sends. In some situations (like an LFO or envelope), this probably won’t have any sonic effect on your patch. But for voltage-critical functions (like an oscillator, where only a slight change in voltage is easily heard), it’s often better to use a buffered mult, since this insures that the 1V/Oct signal arriving at its input will be electrically and accurately duplicated across all its outputs.

Your Palette has two buff mults — one on the left (Buff Mult 1) and another on the right (Buff Mult 2). Each is a stand-alone 1 IN x 4 OUT buffered multiplier. Plug an audio or CV signal into Buff Mult 1’s input jack, and a buffered duplicate of that signal is sent out the four jacks to its right. Similarly, an audio or CV signal patched into Buff Mult 2’s input jack is duplicated at the other four jacks in the group.

The input of Buff Mult 2 is normalled to Buff Mult 1. So if nothing is plugged into Buff Mult 2’s input jack, then the input to Buff Mult 1 is multiplied and sent to all eight outputs, making it act as a single 1 x 8 buffered signal multiplier.

---

## TECHNICAL SPECIFICATIONS

|                      |   |
|----------------------|---|
| Dimensions           | 324.4 x 204.4 x 51.3 (mm)<br>(58.5 mm high, when including rubber feet/jacks)<br>12.77" x 8.05" x 2.02"<br>(2.3" high, when including rubber feet/jacks)<br><br>62 hp for 3U modules + 62 hp for 1U modules |
| Maximum Module Depth | 45.5 mm for middle 60HP<br>37.42mm at each 1HP edge   |
| Current Supplied     | 1.2A @ 12V<br>1.2A @ -12V<br>500mA @ +5V  |