

SPL3220

Stereo Multiband Sound Processor / Loudness Maximizer / Limiter

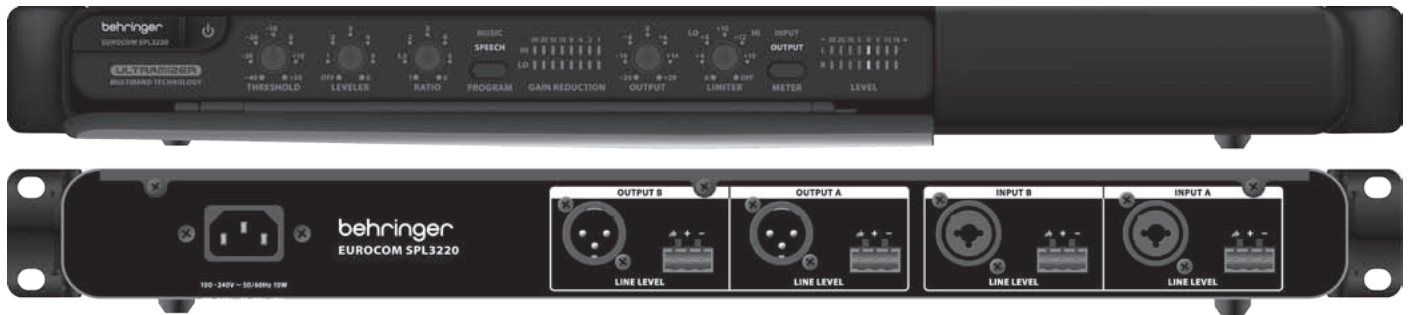

Features

- Professional multiband sound processor for public address, broadcasting and mastering applications
- Multiband technology provides for brilliant and lively audio processing without audible “pumping” artifacts
- Loudness maximization to achieve ultimate signal density for public address and competitive broadcast sound
- Leveler automatically adjusts signal density for harmonized loudness and enhanced listening experience
- Protects speaker systems that are submitted to continuous operation at maximum SPL
- Controls the maximum allowable sound pressure level in public musical environments such as discotheques, pubs, etc.
- Speech enhancer to dramatically increase speech intelligibility for PA applications such as airports and emergency announcement systems
- IKA (Interactive Knee Adaptation) compressor features “inaudible” compression and prevents “pumping” due to low-frequency signals
- IGC (Interactive Gain Control) peak limiting circuitry combines clipper and program limiter for reliable and inaudible protection against signal peaks
- Highly accurate 8-segment input/output level and gain reduction meter
- True stereo operation through RMS energy summing for perfect stereo imaging
- Complies with the certain regulations – unit can be sealed to avoid unauthorized changes to settings
- Two balanced/unbalanced inputs on combination line level XLR/TRS and 3-pin Euroblock connectors
- Operating level switchable from +4 dBu to -10 dBv
- Hinged front door panel covers the control surface plus the power switch
- Rack ear screw covers, IEC-type AC power cord and all mating Euroblock connectors included
- Ultra-light, ultra-low noise and ultra-efficient switch-mode power supply for noise-free audio, superior transient response and low power consumption
- High-quality components and exceptionally rugged construction ensure long life

SPL3220

Stereo Multiband Sound Processor / Loudness Maximizer / Limiter

Technical Specifications

Audio Input

- Type RF filtered, servo-balanced input
- Impedance 60 kOhm
- Nominal Operating Level -10 dBV to +4 dBu
- Max. Input Level +20 dBu balanced and unbalanced
- CMR @ 1 kHz >40dB

Audio Output

- Type electronically servo-balanced output stage (optional transformer-balanced). Automatic level correction for unbalanced use (correction: 6 dB).
- Impedance <40 Ohms, balanced and unbalanced
- Max. Output Level +26 dBm balanced, +20 dBm unbalanced
- Bandwidth 5 Hz to 100 kHz, +0, -3 dB
- THD @ +4 dBu 0.02% typ.
- THD @ +20 dBu 0.1% typ.
- IMD (SMPTE) @ +10 dBu 0.01% typ.
- Noise & Hum. unity gain >-93 dBu (20 Hz to 20 kHz, unweighted)
- Crosstalk @20 kHz >-85 dBu
- CMR @ 1 kHz >40 dB

Crossover Section

- Type 24 dB Butterworth filter
- Corner frequencies switchable (500 Hz / 2 kHz)

Compressor / Leveller Section

- Type Multiband IKA (Interactive Knee Adaptation) Compressor
- THRESHOLD control variable (-40 to +20 dBu)
- LEVELLER control variable (OFF to 6)
- RATIO control variable (1:1 bis 6:1)
- OUTPUT control variable (-20 bis +20 dB)

Peak Limiter Section

- Type Multiband IGC (Interactive Gain Control) Peak Limiter
- LEVEL control variable (0 to +20 dBu)
- BAND LIMIT LEDs Indicators for LOW and HIGH BAND limiter operation

Function Switches

- IN/OUT switch DC controlled "hard -bypass" relay

Indicators

- 8 element GAIN REDUCTION meters 1/2/4/6/10/15/20/30 dB
- 8 element IN/OUT LEVEL meters -30/-20/-10/-5/0/+5/+10/+15 dBu
- LED indicator for each function switch

Power Supply

- Mains Voltages 100 - 240 VAC 50 - 60 Hz
- Power Consumption 10 Watts
- Mains Connection Standard IEC receptacle

Physical

- Dimension 1.7 x 19 x 7.6 " 44.4 x 482.6 x 193 mm
- Net Weight 3 kg
- Shipping Weight 4.3 kg

SPL3220

Stereo Multiband Sound Processor / Loudness Maximizer / Limiter

Controls

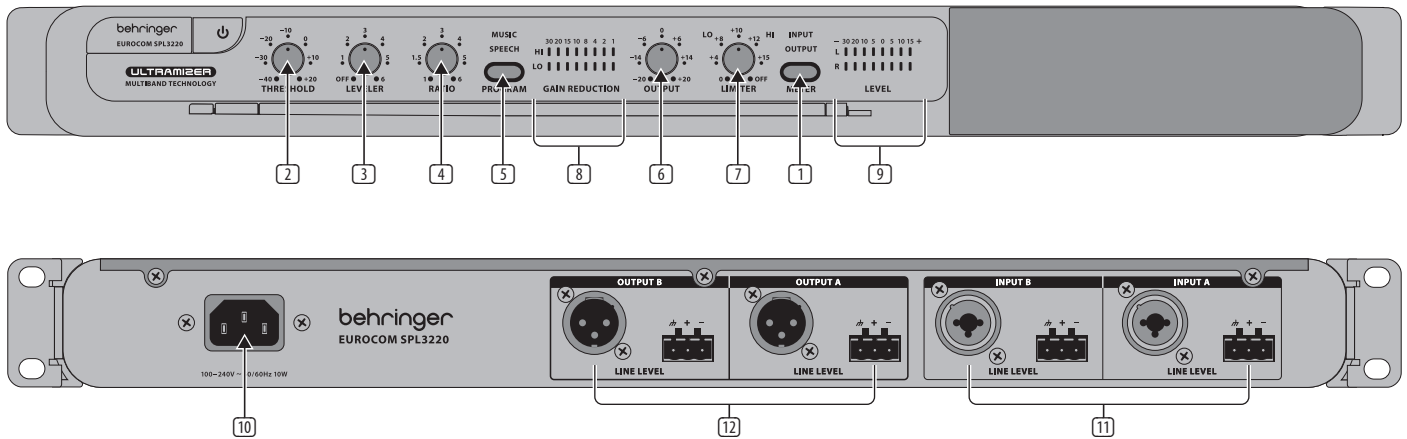

1 IN/OUT switch

This switch activates the relays and engages both channels. The switch has a "hard-bypass" function. This means that when the switch is not depressed (OUT) or the unit is turned off, the input to output connections are direct. The IN/OUT switch is used to make direct A/B comparisons between source material and the processor's effected signal.

2 THRESHOLD control

This control determines the threshold point of the Compressor/Leveller within a range from -40 to +20 dBu. The control function corresponds exactly to the threshold function found in simple broadband devices.

3 LEVELLER control

This control is used to mix in the Leveller function. For the majority of applications, this control should be set to center position; the Leveller will compensate for varying levels in the programme material in order to achieve a consistent compression.

4 RATIO control

The ratio control determines the ratio between the input and output level for all signals exceeding the threshold point. The control range can be adjusted from 1:1 to 6:1.

5 PROGRAM switch

With this switch you determine the crossover frequency of the two bands between music (500 Hz) and speech (2 kHz). For complex signals we recommend the music (500 kHz) setting whereas speech (2 kHz) is preferable to process individual vocals and instruments.

6 OUTPUT control

The OUTPUT control allows for the increase or decrease of the output signal by a maximum of 20 dB. Thus, a level loss due to the compression or limiting process can be compensated for.

7 LIMITER control

This control sets the absolute point by which the output signal is not allowed to go beyond. LO and HI LIMIT LEDs indicate the activity of the individual limiters.

8 GAIN REDUCTION meters

The 8-LED GAIN REDUCTION meters indicate the current gain reduction applied by the individual bands within a range from 0 to 30 dB.

9 INPUT/OUTPUT LEVEL meters

Depending on the setting of the IN/OUT switch, these 8-LED meters inform you either about the input or the output level and monitor them within a range -30 to +15 dBu. If not the IN. OUT switch is set to OUT, the input level is ignored, if set to IN, the meters read the output level. The meter calibration is referenced to +4 dBu.

10 MAINS CONNECTOR

Please use the enclosed mains cable to connect the unit to the mains power supply.

11 INPUT A/B

These are the SPL3220 Line Level audio inputs.

12 OUTPUT A/B

These are the SPL3220 Line Level audio outputs.

SPL3220

Stereo Multiband Sound Processor / Loudness Maximizer / Limiter

Block Diagram

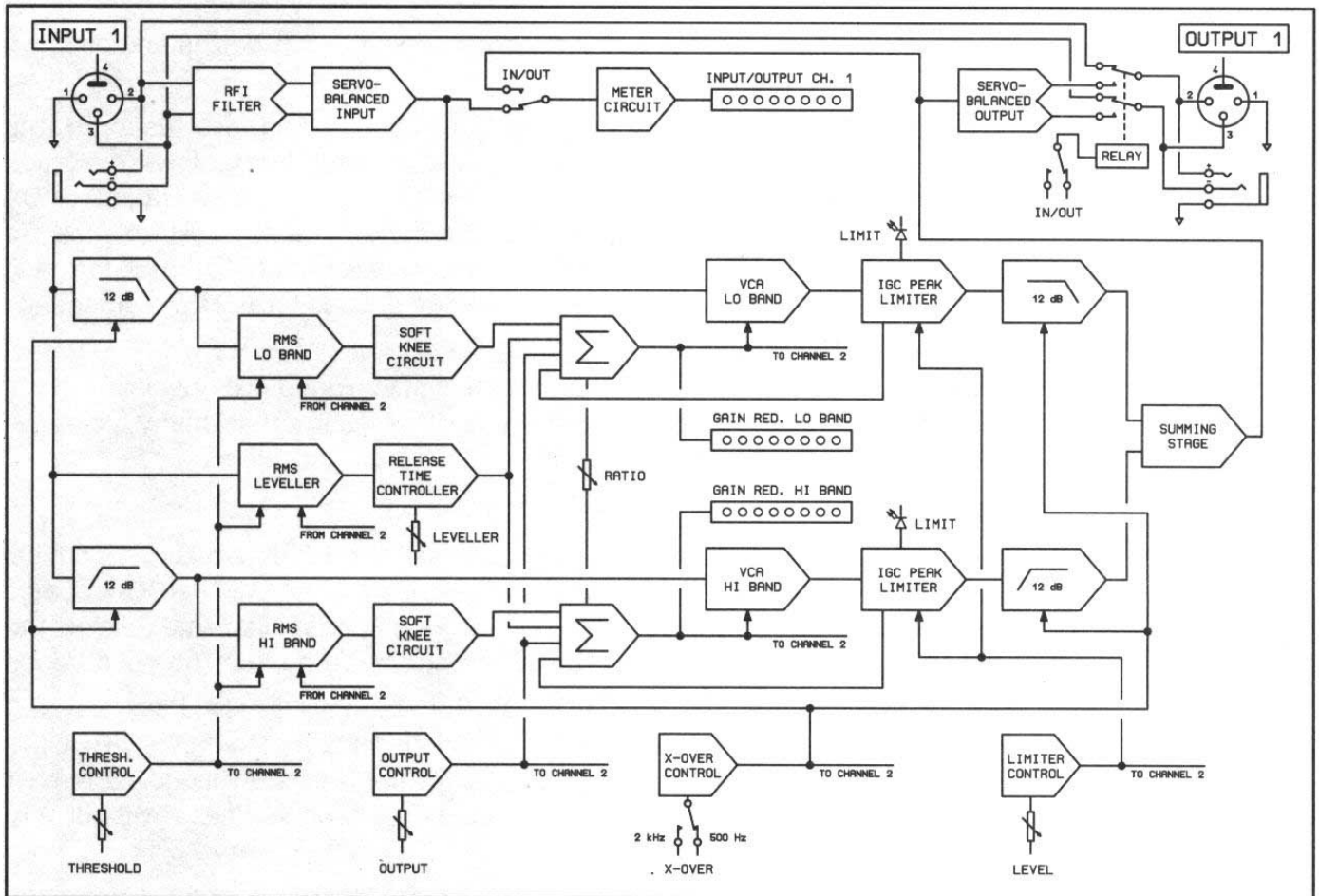

SPL3220

Stereo Multiband Sound Processor / Loudness Maximizer / Limiter

Dimensional Drawings

